

ZONE	REV LTR	DESCRIPTION	E.O.	REVISED BY	DATE	APPR
-	-	ORIGINAL ISSUE		RW	10/30/07	

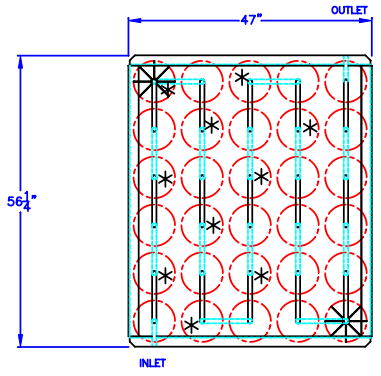

PLAN VIEW

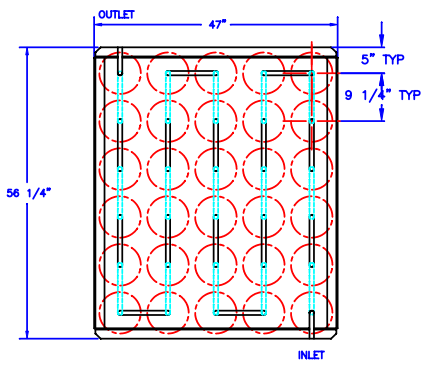

BOTTOM VIEW

THIS DRAWING IS PROPRIETARY INFORMATION PROPERTY OF CRYOGENIC EXPERTS, INC. USE THIS FOR INFORMATION ONLY. DIMENSIONS AND CONNECTION LOCATIONS WILL CHANGE DEPENDING ON THE APPLICATION

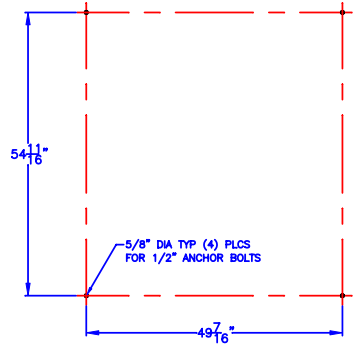

ANCHOR BOLT LAYOUT

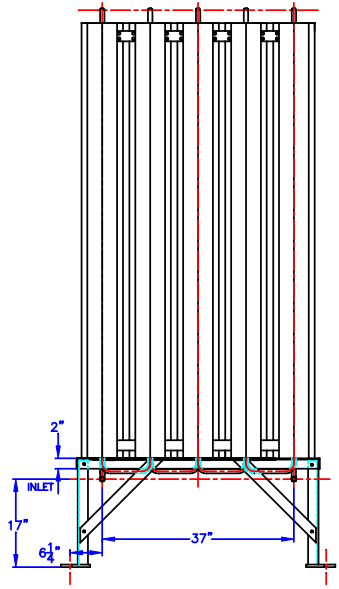

ELEVATION VIEW

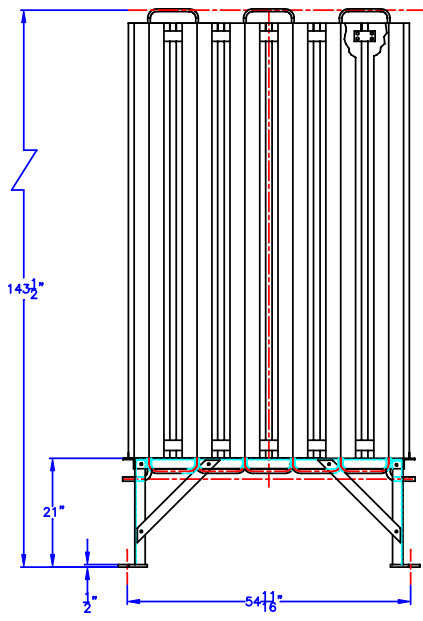

SIDE VIEW

		CRYOGENIC EXPERTS 531 Sandy Circle, El Rio, California 93036 Toll Free 1-800-FOR-CEXI OR Phone (805) 981-4500 Fax. (805) 981-4501			
		UNLESS OTHERWISE NOTED: FRACTIONS ±1/8" DECIMALS X±.1 XX±.03 XXX±.01 ± ° ANGLES BREAK ALL SHARP EDGES DIMENSIONS ARE IN INCHES ORG JOB No. -	APPROVALS DESIGN: KMK CHECKED: MANUF: RELEASED:	DATE 10/30/07	TITLE AMBIENT VAPORIZER GENERAL ARRANGEMENT
FILE -	SCALE 12X	SIZE FSCM NO. B 55429	DWG. NO. A30-10	REV. -	SHEET 1 OF 1