

ZONE	REV LTR	DESCRIPTION	E.O.	REVISED BY	DATE	APPR
-	-	ORIGINAL ISSUE	-	RW	9/24/07	

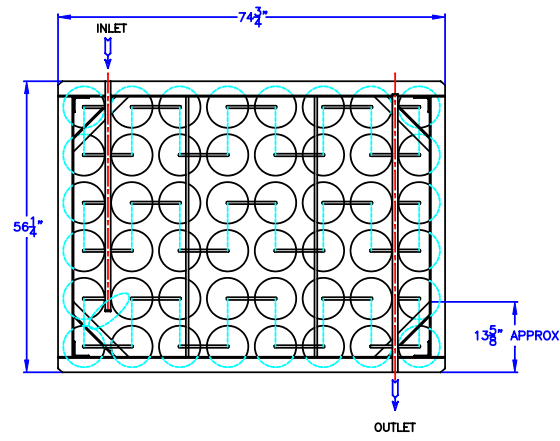

THIS DRAWING IS PROPRIETARY INFORMATION
 PROPERTY OF CRYOGENIC EXPERTS, INC.
 USE THIS FOR INFORMATION ONLY.
 DIMENSIONS AND CONNECTION LOCATIONS
 WILL CHANGE DEPENDING ON THE
 APPLICATION

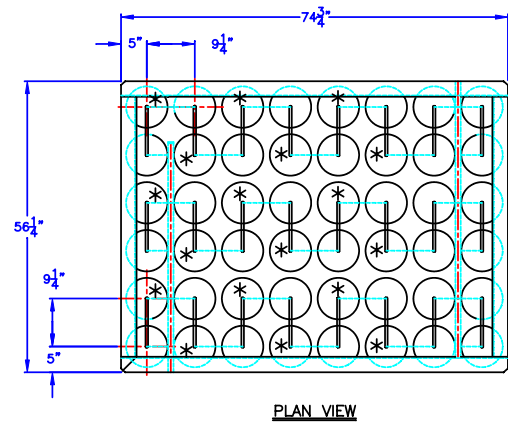
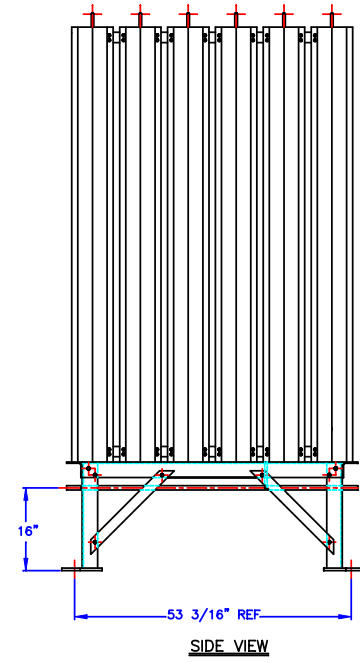
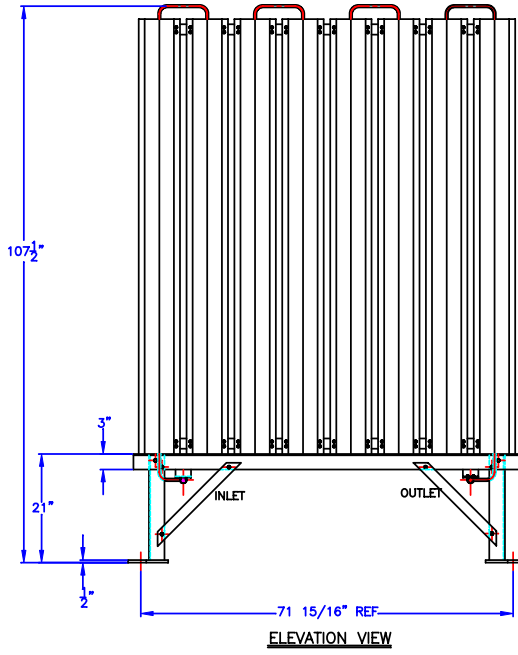
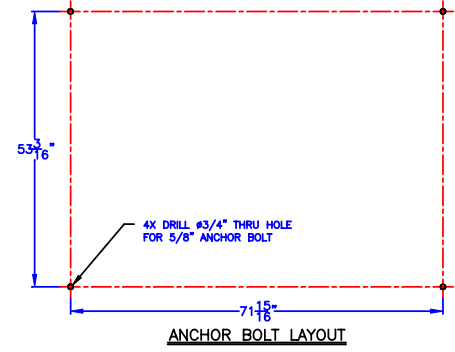

		CRYOGENIC EXPERTS 531 Sandy Circle, El Rio, California 93036 Toll Free 1-800-FOR-CEXI OR Phone (805) 981-4500 Fax. (805) 981-4501			
		UNLESS OTHERWISE NOTED: FRACTIONS ±1/8" DECIMALS X±.1 XX±.03 XXX±.01 ANGLES ±° BREAK ALL SHARP EDGES DIMENSIONS ARE IN INCHES ORG JOB No. - FILE -	APPROVALS DESIGN: KMK CHECKED: MANUF: RELEASED:	DATE 9/24/07	TITLE AMBIENT VAPORIZER GENERAL ARRANGEMENT MODEL A48
		SIZE FSCM NO. B 55429	DWG. NO. A48	REV. -	SCALE 12X JOB NUMBER SHEET 1 OF 1