

ZONE	REV LTR	DESCRIPTION	E.O.	REVISED BY	DATE	APPR
-	-	ORIGINAL ISSUE		RW	12/16/08	

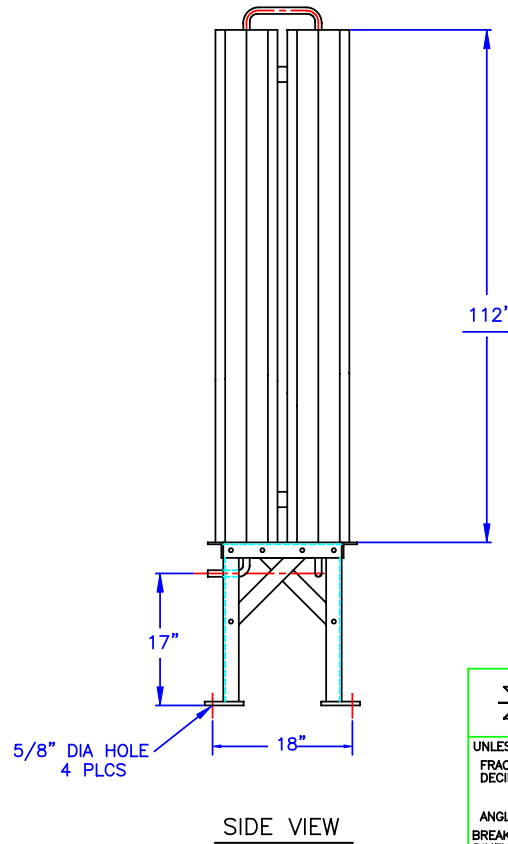

THIS DRAWING IS PROPRIETARY INFORMATION
PROPERTY OF CRYOGENIC EXPERTS, INC.
USE THIS FOR INFORMATION ONLY.
DIMENSIONS AND CONNECTION LOCATIONS
WILL CHANGE DEPENDING ON THE
APPLICATION

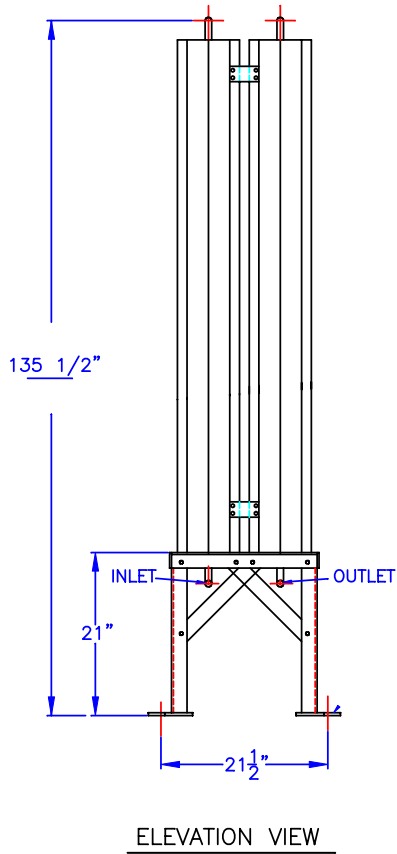
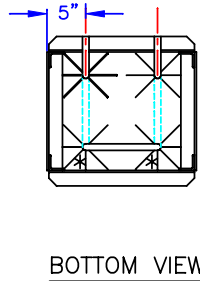
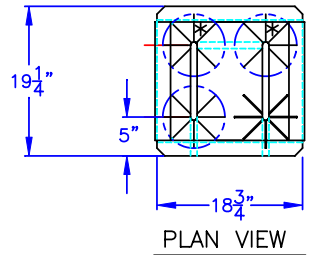
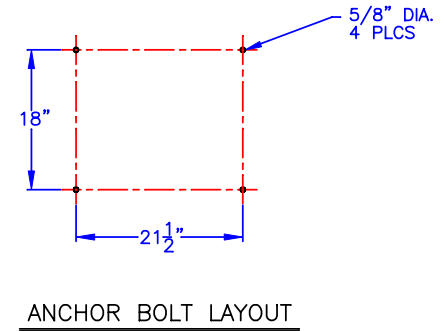

		CRYOGENIC EXPERTS 531 Sandy Circle, El Rio, California 93036 Toll Free 1-800-FOR-CEXI OR Phone (805) 981-4500 Fax. (805) 981-4501			
		UNLESS OTHERWISE NOTED: FRACTIONS ±1/8" DECIMALS X±.1 XX±.03 XXX±.01 ANGLES ±° BREAK ALL SHARP EDGES DIMENSIONS ARE IN INCHES ORG JOB No. - FILE -	APPROVALS DESIGN: KMK CHECKED: MANUF: RELEASED:	DATE 12-16-08	TITLE AMBIENT VAPORIZER GENERAL ARRANGEMENT
		SIZE B	FSCM NO. 55429	DWG. NO. A4SS-9.3	REV. -
		SCALE 6X	JOB NUMBER	SHEET 1 OF 1	