

Tube Trailer Stanchion

Acme Tube Trailer Stanchions are designed to quickly charge or discharge your high pressure tube trailer. Master Shut-off valves and optional single or dual control valves allow you total control over the entire fill.

Dimensions

Aluminum Stand 9' 1-1/4" H x 3' 4-1/4" W
Pigtails 10' or 14'

Features

- Brass or Stainless Steel Construction
- Optional Stainless Steel or Synflex Pigtails
- Master Shut-off Valve
- Reverse Flow Check Valve
- Optional Smart Hose

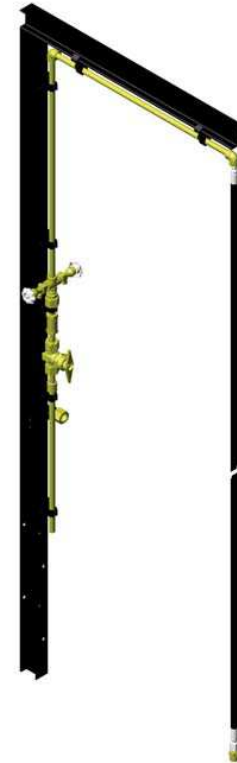

Typical 3,000 PSIG MAWP
Tube Trailer Stanchion

Ordering Information

Service	Charging/ Discharging	Pigtails	Line	Control Valves	Connection	Part Number
Oxygen	Charging	10' Stainless Steel	Single	Single	RH	274-1000
Oxygen	Discharging	10' Stainless Steel	Single	Single	RH	274-1002
Argon	Charging	14' Synflex	Single	Single	RH	274-1100
Argon	Discharging	14' Synflex	Single	Single	RH	274-1101
Helium	Charging	14' Synflex	Single	Single	RH	274-1200
Helium	Discharging	14' Synflex	Single	Single	RH	274-1201
Nitrogen	Charging	14' Synflex	Single	Single	RH	274-1800
Nitrogen	Discharging	14' Synflex	Single	Single	RH	274-1805
Hydrogen	Charging	14' Synflex	Single	Single	LH	274-2600
Hydrogen	Discharging	14' Synflex	Single	Single	LH	274-2603
Hydrogen	Discharging	14' Synflex	Single	Dual	LH	274-2604
Hydrogen	Charging	14' Synflex	Single	Dual	LH	274-2605
Carbon Monoxide	Discharging	10' Stainless Steel	Single	Single	LH	274-2606
Carbon Monoxide	Charging	10' Stainless Steel	Single	Single	LH	274-2607
Hydrogen with Regulator	Discharging	14' Synflex	Single	Single	LH	274-411486

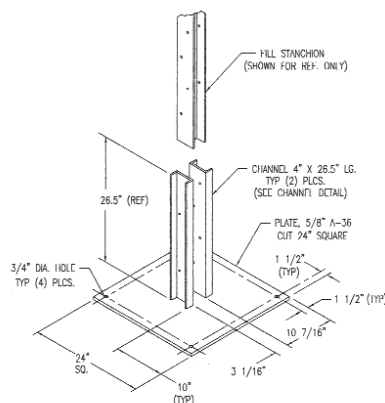

Stand

The Acme Tube Trailer Stanchion Stand is a recommended optional component when ordering your Tube Trailer Stanchion. This stand is made of Galvanized Carbon Steel and designed to support the weight of all of Acme's standard Tube Trailer Stanchions.

Part Number

275-817879